

Northern Illinois University Basic Laser Safety Training

Part 1: Fundamentals of Laser Operation

The He-Ne Laser

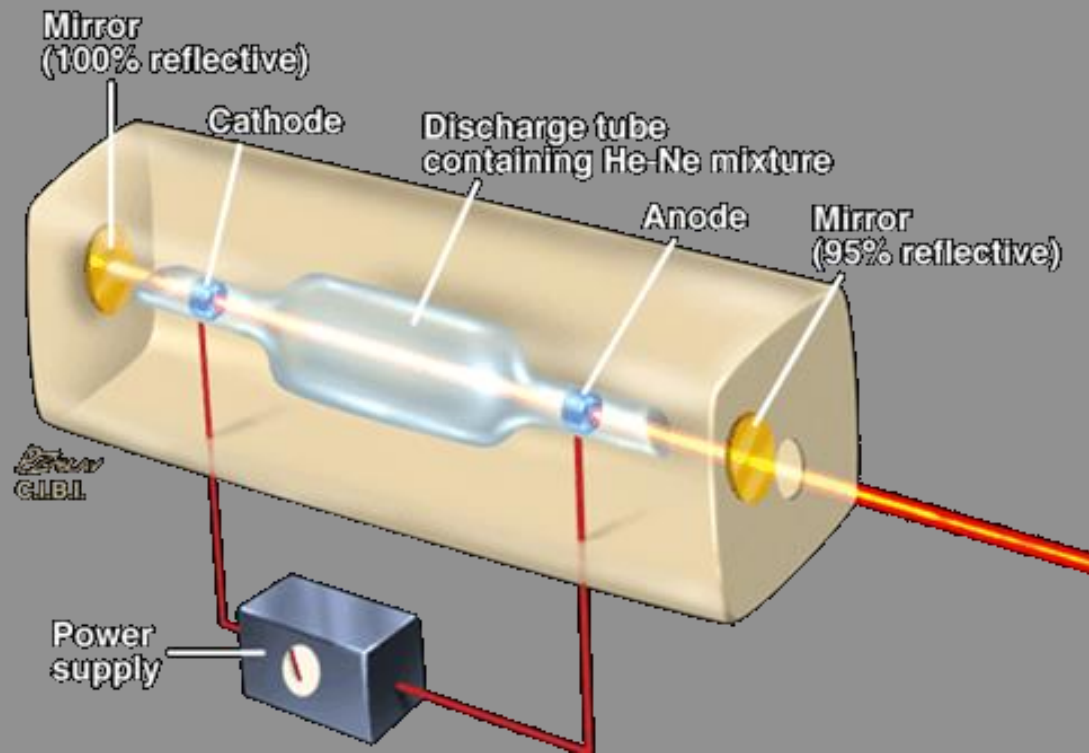

Laser Fundamentals

- The light emitted from a laser is **monochromatic**, that is, it is of one color/wavelength. In contrast, ordinary white light is a combination of many colors (or wavelengths) of light.
- Lasers emit light that is highly **directional**, that is, laser light is emitted as a relatively narrow beam in a specific direction. Ordinary light, such as from a light bulb, is emitted in many directions away from the source.
- The light from a laser is said to be **coherent**, which means that the wavelengths of the laser light are in phase in space and time. Ordinary light can be a mixture of many wavelengths.



These three properties of laser light are what can make it more hazardous than ordinary light. Laser light can deposit a lot of energy within a small area.

Incandescent vs. Laser Light

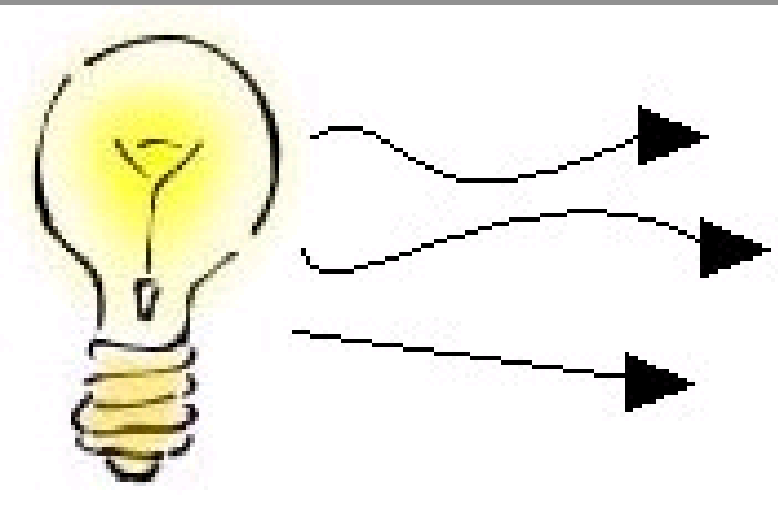

1. Many wavelengths
2. Multidirectional
3. Incoherent

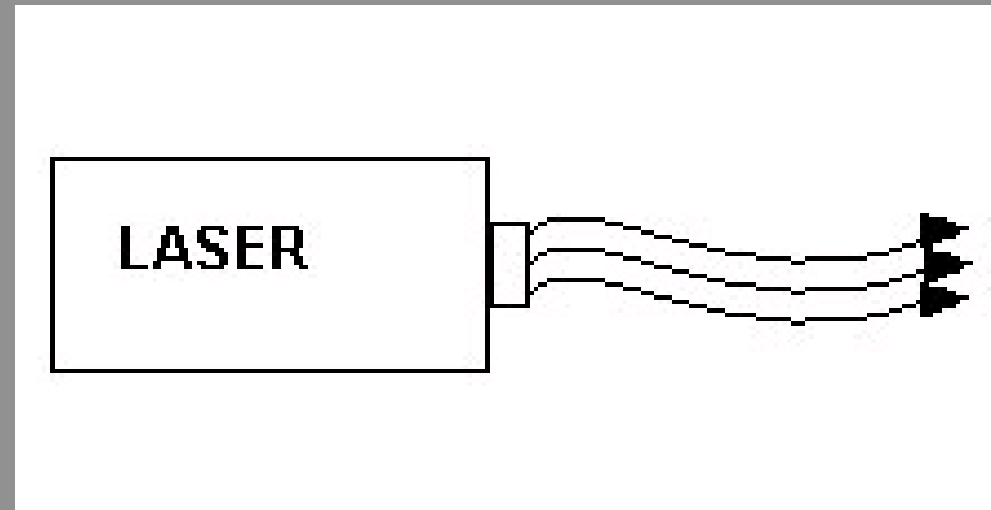

1. Monochromatic
2. Directional
3. Coherent

Common Components of all Lasers

1. Active Medium

The active medium may be solid crystals such as ruby or Nd:YAG, liquid dyes, gases like CO₂ or Helium/Neon, or semiconductors such as GaAs. Active mediums contain atoms whose electrons may be excited to a metastable energy level by an energy source.

2. Excitation Mechanism

Excitation mechanisms pump energy into the active medium by one or more of three basic methods; optical, electrical or chemical.

3. High Reflectance Mirror

A mirror which reflects essentially 100% of the laser light.

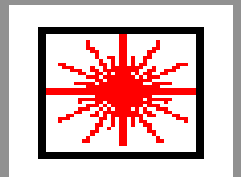

4. Partially Transmissive Mirror

A mirror which reflects less than 100% of the laser light and transmits the remainder.

Laser Components

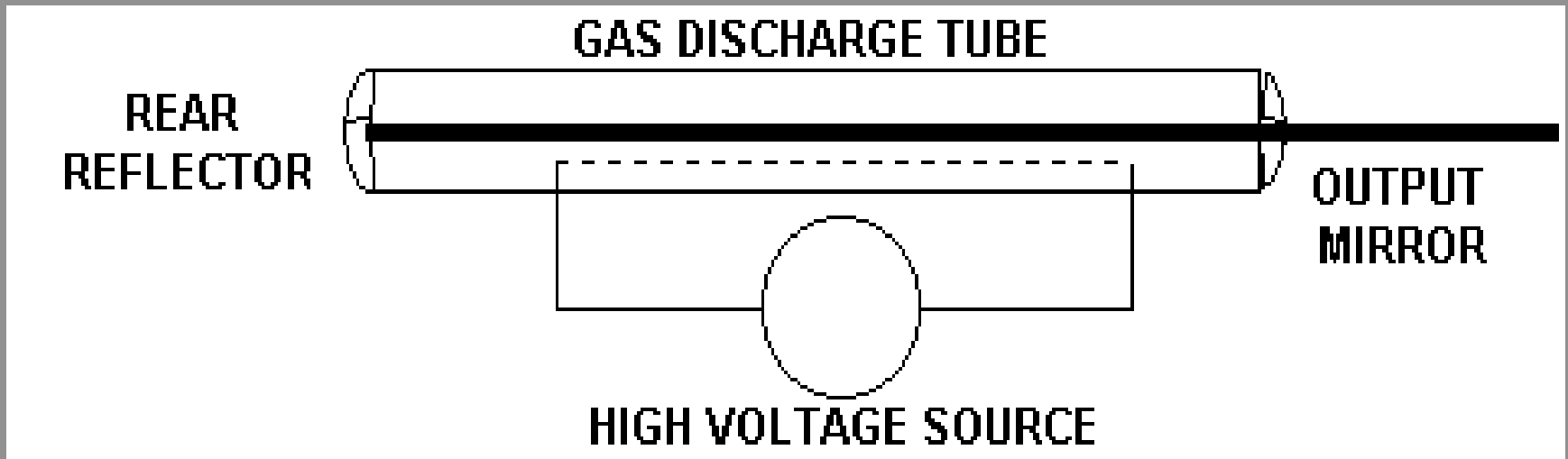

Gas lasers consist of a gas filled tube placed in the laser cavity. A voltage (the external pump source) is applied to the tube to excite the atoms in the gas to a population inversion. The light emitted from this type of laser is normally continuous wave (CW).

Lasing Action

1. Energy is applied to a medium raising electrons to an unstable energy level.
2. These atoms spontaneously decay to a relatively long-lived, lower energy, metastable state.
3. A population inversion is achieved when the majority of atoms have reached this metastable state.
4. Lasing action occurs when an electron spontaneously returns to its ground state and produces a photon.
5. If the energy from this photon is of the precise wavelength, it will stimulate the production of another photon of the same wavelength and resulting in a cascading effect.
6. The highly reflective mirror and partially reflective mirror continue the reaction by directing photons back through the medium along the long axis of the laser.
7. The partially reflective mirror allows the transmission of a small amount of coherent radiation that we observe as the “beam”.
8. Laser radiation will continue as long as energy is applied to the lasing medium.

Lasing Action Diagram

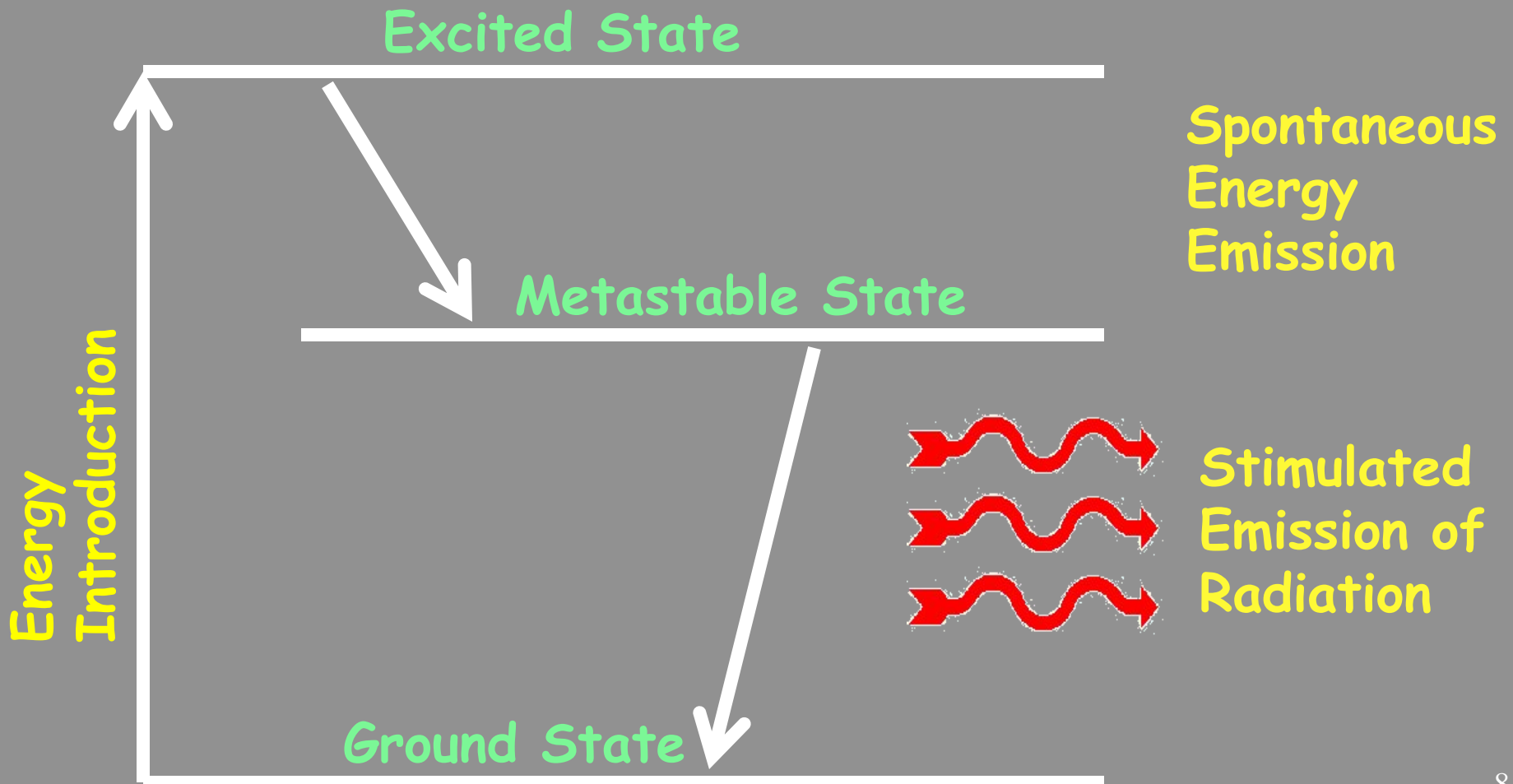

HR
High Reflector
(Totally Reflecting)

Laser Resonator consists of Lasing Medium (gas, liquid, or solid) between HR and OC Mirrors.

OC
Output Coupler
(Partially Reflecting)

1

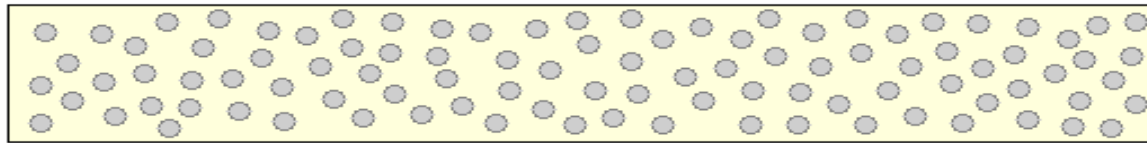

Lasing Medium at Ground State

Pump Energy (Electrical, Optical, Chemical, etc.)



2

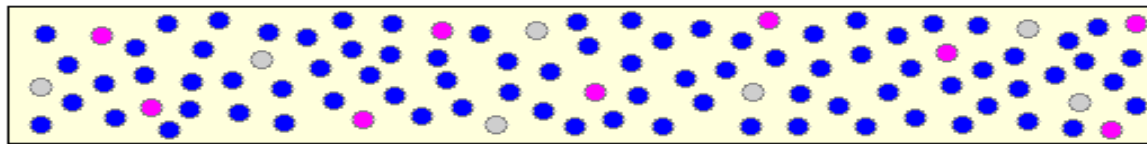

Population Inversion

3

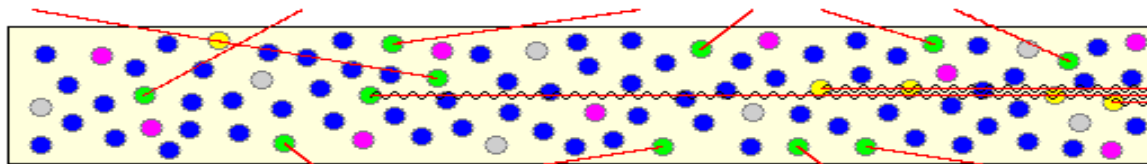

Spontaneous Emission, Start of Stimulated Emission

4

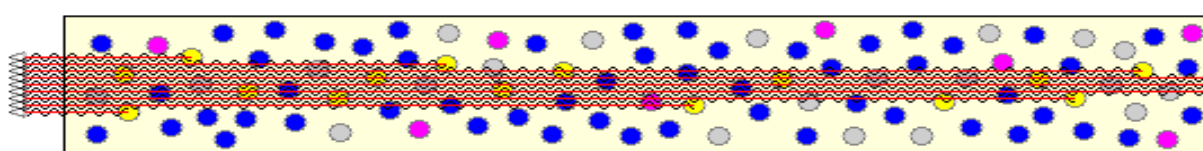

Stimulated Emission Building Up

5

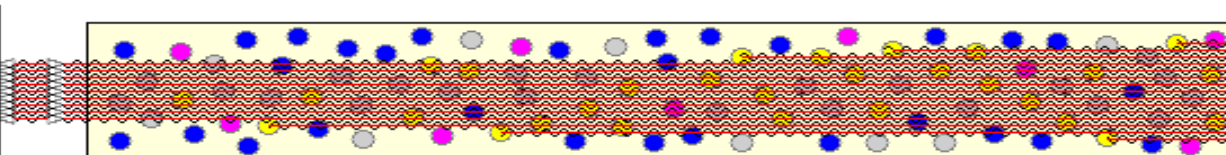

Full Stimulated Emission, Coherent Laser Beam Generated

Legend:

- Ground State
- Energy Level 1
- Energy Level 2
- Spontaneous Emission
- Stimulated Emission

The ● are atoms, ions, or molecules depending on lasing medium.

Laser Beam

Basic Laser Operation

WAVELENGTHS OF MOST COMMON LASERS

<u>Laser Type</u>	<u>Wavelength (μm)</u>		
Argon fluoride (Excimer-UV)	0.193	Helium neon (yellow)	0.594
Krypton chloride (Excimer-UV)	0.222	Helium neon (orange)	0.610
Krypton fluoride (Excimer-UV)	0.248	Gold vapor (red)	0.627
Xenon chloride (Excimer-UV)	0.308	Helium neon (red)	0.633
Xenon fluoride (Excimer-UV)	0.351	Krypton (red)	0.647
Helium cadmium (UV)	0.325	Rhodamine 6G dye (tunable)	0.570-0.650
Nitrogen (UV)	0.337	Ruby (CrAlO_3) (red)	0.694
Helium cadmium (violet)	0.441	Gallium arsenide (diode-NIR)	0.840
Krypton (blue)	0.476	Nd:YAG (NIR)	1.064
Argon (blue)	0.488	Helium neon (NIR)	1.15
Copper vapor (green)	0.510	Erbium (NIR)	1.504
Argon (green)	0.514	Helium neon (NIR)	3.39
Krypton (green)	0.528	Hydrogen fluoride (NIR)	2.70
Frequency doubled Nd YAG (green)	0.532	Carbon dioxide (FIR)	9.6
Helium neon (green)	0.543	Carbon dioxide (FIR)	10.6
Krypton (yellow)	0.568		
Copper vapor (yellow)	0.570		

Key: UV = ultraviolet (0.200-0.400 μm)
 VIS = visible (0.400-0.700 μm)
 NIR = near infrared (0.700-1.400 μm)

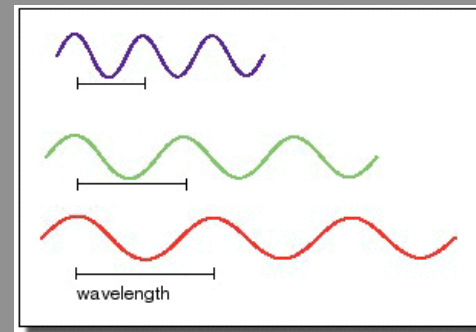

Laser Output

Continuous Output (CW)

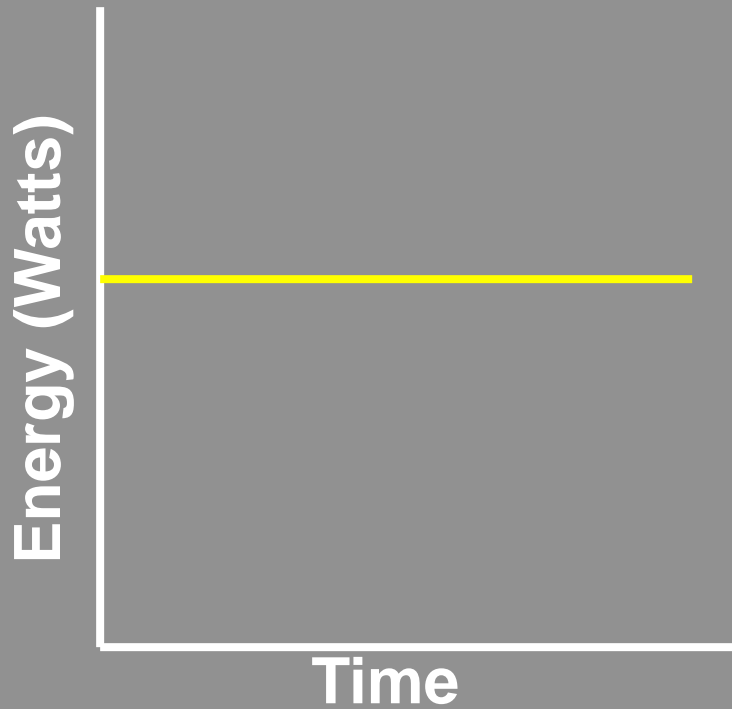

Pulsed Output (P)

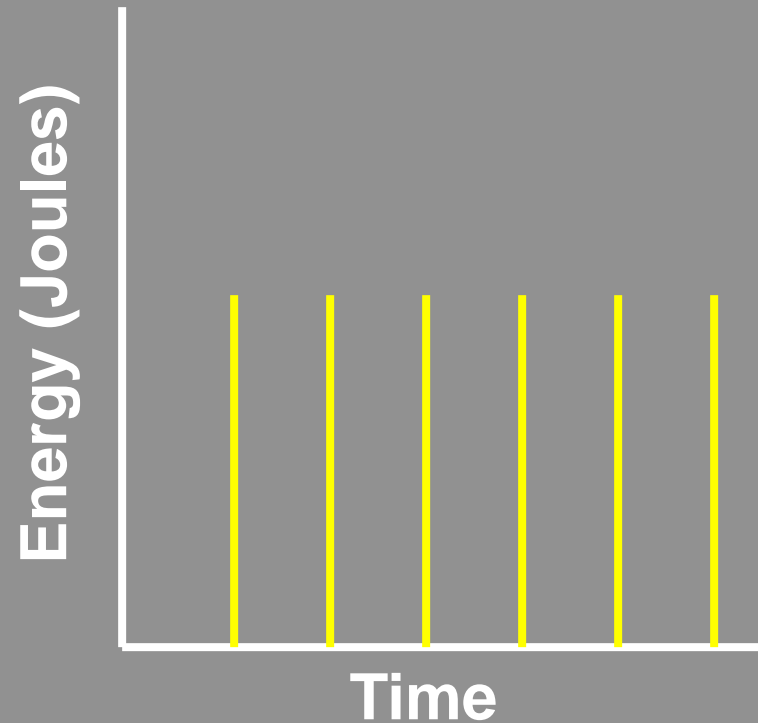

watt (W) - Unit of power or radiant flux (1 watt = 1 joule per second).

Joule (J) - A unit of energy

Energy (Q) The capacity for doing work. Energy content is commonly used to characterize the output from pulsed lasers and is generally expressed in Joules (J).

Irradiance (E) - Power per unit area, expressed in watts per square centimeter.

Part 2: Laser Hazards

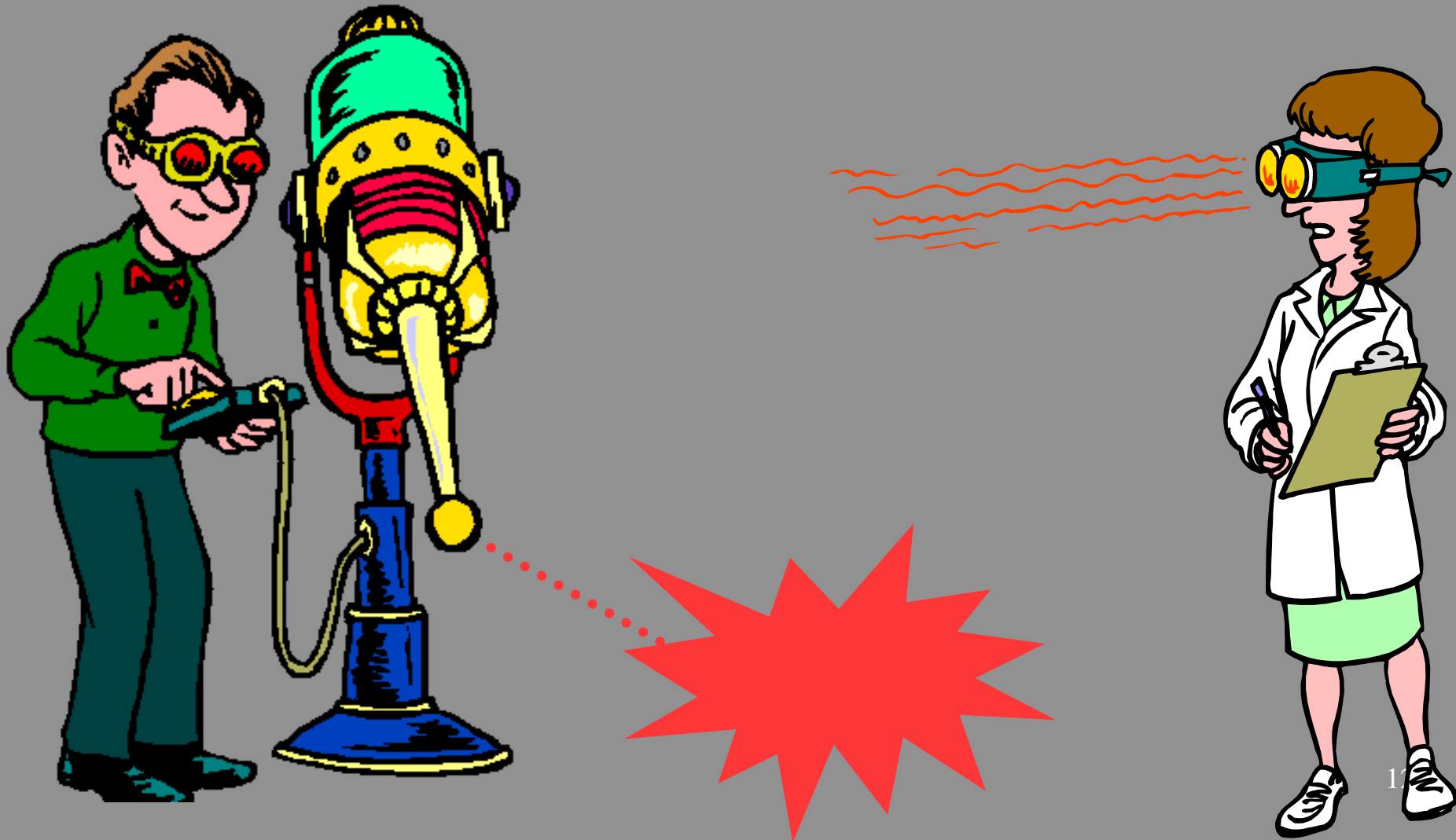

Types of Laser Hazards

1. **Eye** : Acute exposure of the eye to lasers of certain wavelengths and power can cause corneal or retinal burns (or both). Chronic exposure to excessive levels may cause corneal or lenticular opacities (cataracts) or retinal injury.
2. **Skin** : Acute exposure to high levels of optical radiation may cause skin burns; while carcinogenesis may occur for ultraviolet wavelengths (290-320 nm).
3. **Chemical** : Some lasers require hazardous or toxic substances to operate (i.e., chemical dye, Excimer lasers).
4. **Electrical** : Most lasers utilize high voltages that can be lethal.
5. **Fire** : The solvents used in dye lasers are flammable. High voltage pulse or flash lamps may cause ignition. Flammable materials may be ignited by direct beams or specular reflections from high power continuous wave (CW) infrared lasers.

Lasers and Eyes

- What are the effects of laser energy on the eye?
 - ◆ Laser light in the visible to near infrared spectrum (i.e., 400 - 1400 nm) can cause damage to the retina resulting in scotoma (blind spot in the fovea). This wave band is also known as the "retinal hazard region".
 - ◆ Laser light in the ultraviolet (290 - 400 nm) or far infrared (1400 - 10,600 nm) spectrum can cause damage to the cornea and/or to the lens.
- Photoacoustic retinal damage may be associated with an audible "pop" at the time of exposure. Visual disorientation due to retinal damage may not be apparent to the operator until considerable thermal damage has occurred.

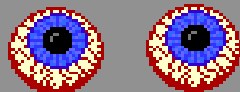

Symptoms of Laser Eye Injuries

- Exposure to the invisible *carbon dioxide laser* beam (10,600 nm) can be detected by a burning pain at the site of exposure on the cornea or sclera.
- Exposure to a visible laser beam can be detected by a bright color flash of the emitted wavelength and an after-image of its complementary color (e.g., a green 532 nm laser light would produce a green flash followed by a red after-image).
- *The site of damage depends on the wavelength of the incident or reflected laser beam:*
- When the retina is affected, there may be difficulty in detecting blue or green colors secondary to cone damage, and pigmentation of the retina may be detected.
- Exposure to the *Q-switched Nd:YAG laser* beam (1064 nm) is especially hazardous and may initially go undetected because the beam is invisible and the retina lacks pain sensory nerves.

Skin Hazards

- Exposure of the skin to high power laser beams (1 or more watts) can cause burns. At the under five watt level, the heat from the laser beam will cause a flinch reaction before any serious damage occurs. The sensation is similar to touching any hot object, you tend to pull your hand away or drop it before any major damage occurs.
- With higher power lasers, a burn can occur even though the flinch reaction may rapidly pull the affected skin out of the beam. These burns can be quite painful as the affected skin can be cooked, and forms a hard lesion that takes considerable time to heal.
- Ultraviolet laser wavelengths may also lead to skin carcinogenesis.

Other Hazards Associated with Lasers

Chemical Hazards

Some materials used in lasers (i.e., excimer, dye and chemical lasers) may be hazardous and/or contain toxic substances. In addition, laser induced reactions can release hazardous particulate and gaseous products.

(Fluorine gas tanks)

Electrical Hazards

Lethal electrical hazards may be present in all lasers, particularly in high-power laser systems.



Secondary Hazards including:

- cryogenic coolant hazards
- excessive noise from very high energy lasers
- X radiation from faulty high-voltage (>15kV) power supplies
- explosions from faulty optical pumps and lamps
- fire hazards



Part 3: Classification of Lasers and Laser Systems



Laser Safety Standards and Hazard Classification

- Lasers are classified by hazard potential based upon their optical emission.
- Necessary control measures are determined by these classifications.
- In this manner, unnecessary restrictions are not placed on the use of many lasers which are engineered to assure safety.
- In the U.S., laser classifications are based on American National Standards Institute's (ANSI) Z136.1 Safe Use of Lasers.

Laser Class

The following criteria are used to classify lasers:

1. **Wavelength**. If the laser is designed to emit multiple wavelengths the classification is based on the most hazardous wavelength.
2. For continuous wave (CW) or repetitively pulsed lasers the **average power output** (Watts) and **limiting exposure time** inherent in the design are considered.
3. For pulsed lasers the **total energy per pulse** (Joule), **pulse duration**, **pulse repetition frequency** and **emergent beam radiant exposure** are considered.

ANSI Classifications

- **Class 1** denotes laser or laser systems that do not, under normal operating conditions, pose a hazard.

Class 2 denotes low-power visible lasers or laser system which, because of the normal human aversion response (i.e., blinking, eye movement, etc.), do not normally present a hazard, but may present some potential for hazard if viewed directly for extended periods of time (like many conventional light sources).

ANSI Classifications (cont'd)

- **Class 3a** denotes some lasers or laser systems having a CAUTION label that normally would not injure the eye if viewed for only momentary periods (within the aversion response period) with the unaided eye, but may present a greater hazard if viewed using collecting optics. Class 3a lasers have DANGER labels and are capable of exceeding permissible exposure levels. If operated with care Class 3a lasers pose a low risk of injury.
- **Class 3b** denotes lasers or laser systems that can produce a hazard if viewed directly. This includes intrabeam viewing of specular reflections. Normally, Class 3b lasers will not produce a hazardous diffuse reflection.
- **Class 4** denotes lasers and laser systems that produce a hazard not only from direct or specular reflections, but may also produce significant skin hazards as well as fire hazards.

Hazard Evaluation- Reflections

Specular reflections are mirror-like reflections and can reflect close to 100% of the incident light. Flat surfaces will not change a fixed beam diameter only the direction. Convex surfaces will cause beam spreading, and concave surfaces will make the beam converge.

Diffuse reflections result when surface irregularities scatter light in all directions. The specular nature of a surface is dependent upon the wavelength of incident radiation. A specular surface is one that has a surface roughness less than the wavelength of the incident light. A very rough surface is not specular to visible light but might be to IR radiation of 10.6 μm from a CO₂ laser.

Reflection Hazards (cont'd)

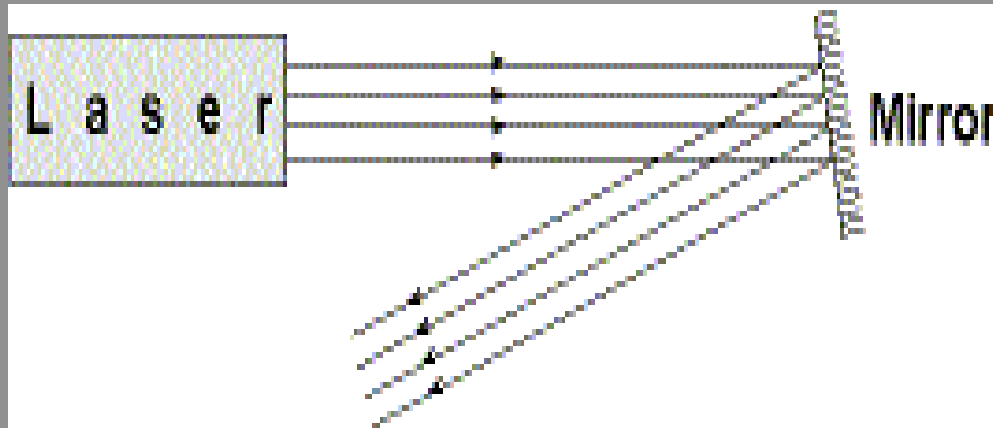

**Specular
Reflection**

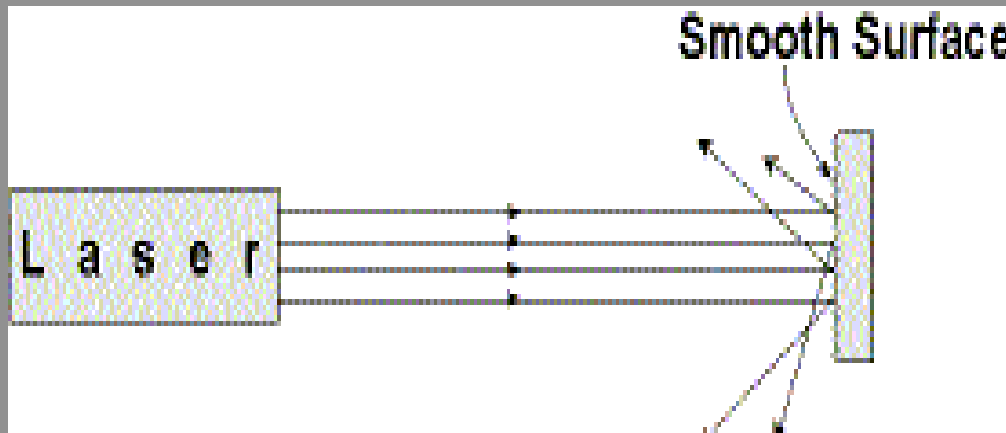

**Diffuse
Reflection**

Hazard Terms

Maximum Permissible Exposure (MPE)

The MPE is defined in ANSI Z-136.1 "The level of laser radiation to which a person may be exposed without hazardous effect or adverse biological changes in the eye or skin."

The MPE is not a distinct line between safe and hazardous exposures. Instead they are general maximum levels, to which various experts agree should be occupationally safe for repeated exposures.

The MPE, expressed in $[J/cm^2]$ or $[W/cm^2]$, depends on the laser parameters:

- wavelength,
- exposure duration,
- pulse Repetition Frequency (PRF),
- nature of the exposure (specular, diffuse reflection).

Hazard Terms (cont'd)

Nominal Hazard Zone (NHZ)

In some applications open beams are required, making it necessary to define an area of potentially hazardous laser radiation.

This area is called the nominal hazard zone (NHZ) which is defined as a space within which the level of direct, scattered, or reflected laser radiation exceeds the MPE.

The purpose of a NHZ is to define an area in which control measures are required.

**GOGGLES
MUST BE
WORN BEYOND
THIS POINT**

Part 4: Control Measures and Personal Protective Equipment



CONTROL MEASURES

Engineering Controls

- ✓ Interlocks
- ✓ Enclosed beam

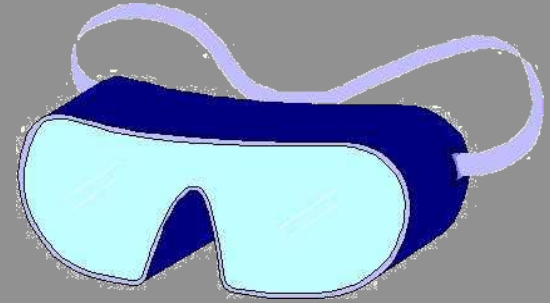

Administrative Controls

- ✓ Standard Operating Procedures (SOPs)
- ✓ Training

Personnel Protective Equipment (PPE)

- ✓ Eye protection

Laser Protective Eyewear Requirements

1. Laser Protective eyewear is to be available and worn in by all personnel within the Nominal Hazard Zone (NHZ) of Class 3 b and Class 4 lasers where the exposures above the Maximum Permissible Exposure (MPE) can occur.
2. The attenuation factor (optical density) of the laser protective eyewear at each laser wavelength should be specified by the Laser Safety Officer (LSO).
3. All laser protective eyewear shall be clearly labeled with the optical density and the wavelength for which protection is afforded. This is especially important in areas where multiple lasers are housed.
4. Laser protective eyewear shall be inspected for damage prior to use.

Optical Density (OD)

The OD (absorbance) is used in the determination of the appropriate eye protection. OD is a logarithmic function.

Common Laser Signs and Labels

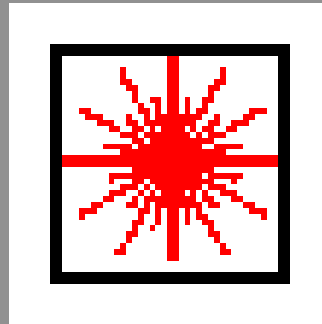

Laser Safety Contact Information

Michele Crase
Laser Safety Officer
(815) 753-9251 office
(815) 751-4294 cell
mcrase@niu.edu



Office of Research Compliance and
Integrity
(815) 753-8588

Thank you to University of South Florida, Laser Training Program